

Insulated and Covered Conductors Systems for Low and Medium voltage Over head distribution line

SUPREME & CO. PVT. LTD.

53, Justice Chandra Madhav Road, Kolkata - 700020. India.
Ph: 91-33-24748575 / 7565 | Fax: 91-33-2476-1955
Email: sales@supremeco.com | www.supremeco.com

Insulated and covered conductor systems for Low and medium voltage over head distribution lines

H.K.Agarwal (Supreme & Co), P.Barua (Supreme & Co.)

Overhead distribution systems can be categorized into two broad heads based on voltage rating and insulation system. Distribution system based on voltage rating is broadly either low voltage (upto 1.1 KV) or medium voltage (upto 36 kV). Transmission and sub-transmission of power is done at higher voltages. Voltages between 33kV and about 230kV, called high voltage are used for sub-transmission & transmission of power. Voltage level above 230kv upto about 800kv is called EHV or Extra High Voltage and voltage level above 800kv is called UHV or Ultra High Voltage.

We now also have HVDS systems where lines right upto consumer's small single phase transformers are run at medium voltage. In this system LV mains are conspicuous by their absence. Categories based on insulation type are either bare or covered.

In case of bare lines most of the insulation is provided by air and the insulators are used to support and dead end conductor on poles and pylons with the help of tension strings and support hardware. Insulators also prevent leakage of current between conductor & supports. Spacing between phases and vertical ground clearance are critical safety requirements. Insulated spacers are also sometimes used to maintain inter-phase spacing and to prevent accidental contact between them.

In case of LV applications, fully insulated ABC system is increasingly becoming the most acceptable option with a perfect fit in the equation of cost/ quality binomial. Main features / advantages of low voltage ABC system are being separately outlined here.

Medium Voltage: For Medium Voltages two popular non-bare conductor systems are in use in different parts of the World. With development in Water proofing, vibration and arc protecting of covered conductors, unscreened covered conductors although not fully insulation rated and touch proof ,are being extensively used on account of reduced requirements of spacing between conductors and obviating outages on account of accidental contact of phases or falling trees.

It has also been noted during trials in Norway that "quite apart from much reduced way leaves that such a line then requires, the weight of a fallen tree or wind-blown object falling on the three covered phases, strung on a horizontal cross arm one third of the length of the bare line norm, considerably reduces the torque on the pole, when compared with the bare line."²

Fully insulated metallic screened MV ABC System has been used in India in mainly in HVDS systems. Internationally also MV ABC has been technically the best solution where there are constraints on availability of tree clearances, bush fire risk areas with overhanging trees, highly congested localities, vulnerability to power thefts. These cables are shielded & screened and the insulation is designed and tested to confine full operating voltage. The different layers of insulation, voltage stress-relief, anti-tracking and metallic shield provide a designated path for fault and charging current to flow in case of insulation failure. Such system require voltage stress-relief terminations at every joint, termination and tap.

Problems while erecting these lines stem from A) Making Tees at discontinuities B) Difficulty in access to conductor for testing and Earthing maintenance. C) Operations, Switching, Earthing practice significantly different from the ones followed for Bare conductor mains and in fact closer to the ones followed by underground system requiring extensive training for installation and maintenance personnel.

Utilities in different parts of the world like Brazil, Sweden, Australia, Ireland, UK, have concurrently used medium voltage covered system and ABC insulated system as trial or regular basis. Fully insulated metallic screened ABC system has found limited usage on account of prohibitive cost. It has mostly found applications where medium voltage lines have to be taken through confined spaces near congested houses & buildings sites or other obstructions. In such cases, public safety and "safe to touch" system is the over riding need. In India, this system has been installed by a number of utilities. As explained above this has been very suitable for taking HVDS lines through slums to be connected to small capacity single phase transformers.

Covered, unscreened conductors are most commonly in use as outage-free alternative to bare lines. In North America and Brazil, they use composite spacers to maintain horizontal separation. In Europe the system has many designations based on protection arrangement and voltage rating. Spacer cable lines, according to study publishers in T&D world on Nov 1, 1997 by Mauricio R. Soares of CEMIG, operating from five to six years, faced only two accidental outages. The conductors ruptured due to a falling object from the building, and the extended rubbing of a covered cable against a tree branch. These interruptions represent an average ratio of 0.3 failure/Km/year. While main advantages are narrow corridor and negligible outages, on the flip side, it still needs vertical clearance of bare lines as the system is not touch free. Another system finding increasing acceptance is MV bundled system with a Semi-conducting outer layer with no metallic screen and a bare messenger wire. The "touch-safe" property of the bundle is achieved by connecting bare messenger to earth. This system has been found attractive in Ireland based on feedback of Australian experience.²³ This drastically cut-down the cost of cable as also the weight of cable resulting in reduction of mechanical load on structures and support hardware.

FEATURES OF LV ABC SYSTEM

- The phase conductors are fully insulated. The messenger may be either bare or insulated depending on type of system being followed

- More than one conductor is part of the bundle. Commonly they are four comprising of three phases and one neutral messenger. Very often 5th conductor can be used for street lighting is also a part of the bundle.
- They are self-supporting and suspended between supports (generally existing poles)
- They can be installed through forest areas without cutting of aisles prescribed for overhead lines.
- ABC Bundle and accessories being fully insulated protect lineman actively as the design is touch proof.
- They are twisted together to form a bundle as there is no requirement of phase to phase clearance. Individual cores are separated only at dead ends, supports, joints and tap-offs.
- Prescribed clearance required for Bare Conductors under NEC/NESC/VDE/EDF codes not applicable here and the same may be reduced without limitation as long as insulation does not become vulnerable to mechanical damage.
- The conductors and joints are fully water proof. All joints and taps are required by most standards to be tested to withstand 6 kV RMS while being immersed in water of defined maximum resistivity and prescribed minimum pressure.
- Lower voltage drop and higher current carrying capacity. For supply cases vulnerable to voltage problem the use of ABC system increases transmission capacity because of very low inductive resistance as compared to ohmic resistance.

Types of Insulated Overhead Cable Systems

Finnish System

Insulated aluminium phase conductors. Bare aluminium alloy messenger wire, which is also the neutral conductor. The cable can also have separate conductors for street lighting.

French System

Phase conductors are insulated aluminium wire. Messenger wire is insulated aluminium alloy. The bundle may have separate core for street lighting.

German System

Four equal insulated aluminium alloy conductors, includes phase -and neutral conductors. The cable can also have separate conductors for street lighting.

Types of Insulated overhead cable systems - A Comparison

Features	Finnish System	French System	German System
Rated MFL for conductors	3x35+50mm.sq.=14.7 kN 3x70mm.sq.+95mm.sq.=27.9kN 3x120mm.sq.+95mm.sq.=27.9kN	3x35mm.sq.+54.6mm.sq.=16.6 kN 3x70mm.sq.+54.6mm.sq.=16.6 kN 3x120mm.sq.+70mm.sq.=20.5kN	4x25mm.sq = 16.7 kN 4x50mm.sq. = 33.2kN 4x 70mm.sq. = 45.3kN 4x95mm.sq. 60.8kN 4x120mm.sq.=75.1kN
Distribution of mechanical load	Messenger wire carries all mechanical load	Messenger wire carries all mechanical load	Mechanical load applied in all conductors.
Tensile strength of wires of conductor (N/mm.sq.)	Neutral 300N/mm.sq. Phase 120N/mm.sq.	Neutral 300N/mm.sq. Phase 120N/mm.sq.	All conductors 160N/mm.sq.
Messenger Failure and Earthing considerations	The neutral is reinforced, but it may break singularly as sole core under tension. Risk to personal and apparatus due to rise in phase voltage and high potential in neutral, if not properly earthed.	The neutral may break alone, if not provided with weak links. Risk to personnel and apparatus due to rise in phase voltage and high potential in neutral, if the earthing is not made properly.	The neutral is unlikely to break alone, if the installation is made properly. High mechanical strength.
Live line work	Normal requirements. Uninsulated neutral may have touch voltage in poor earthing conditions. Proper earthing is essential.	Normal requirement	Normal requirement
Risk of corrosion in the neutral	Potential risk in extreme climate conditions	Reduced risk	Reduced risk

Insulation Piercing Connectors

One of the most important component of LV - ABC system is the use of Insulation piercing connector. It is by far the most critical component and a fitting of poor design or workmanship is doomed to be proved the weak link of the system. Insulation piercing is a technology that has evolved over a period of more than three decades and in some ways it is still evolving. It progressed from a design where both run and tap conductors were stripped and subsequently insulated by using a thermoplastic rigid cover with IP rating of 23. It progressed to connectors that pierced the main , requiring only the tap to be stripped. Rigid covers gave way to flexible material being used to for covers which would not break in cold climates. Design

of piercing teeth progressed from pyramidal shape machined from an aluminium alloy profile to extruded knife shape to the use of copper/ aluminium alloy contact blades. Contact blades became amenable to encapsulation by a rubber seals which were water tight. Validation of water tightness by flashover test of 6KV RMS in water was a major development in the field of water proof connections with degree of protection rating up to IP 68. A parallel development leading to use of reliable shear heads was a major step forward in the area of contact reliability by affording optimum torque on the clamping bolts.

New generation insulation piercing connectors are integrally constructed electro-mechanical devices with no loose parts with thermoplastic UV stabilized housing to provide insulation, corrosion resistant metallic bolts for clamping, metallic contact blades for low resistance contacts, rubber seals to ensure water tightness, grease to prevent oxidation, shear heads for controlling torque and end caps for sealing cable ends.

Features of Insulation Piercing Connectors

Water Proof insulation piercing connectors have following features:

- 1) It is provided with piercing teeth of copper/aluminum for high-conductivity connection. The teeth may be tin plated to limit bi-metallic reaction with Aluminum cores.
- 2) Insulation piercing connectors provides connection between main and derived Cable by perforation of insulation.
- 3) Suitable grease is provided on teathed blade to prevent surface oxidation.
- 4) Piercing of main and derived is simultaneous with one action.
- 5) Piercing teeth and pierced cables are protected from water entry by in built seals around the conductor teeth.
- 6) Bolts are provided with head which functions as a torque controlling device. Shear head across flats are standardized at 13mm or 17mm to minimize the number of tooling required
- 7) A2 or A4 grade stainless Steel bolt or high strength galvanized steel bolts are used
- 8) Insulated jackets are UV resistant fiber glass reinforced thermoplastic
- 9) Rated for test voltage 6 kv RMS in water.

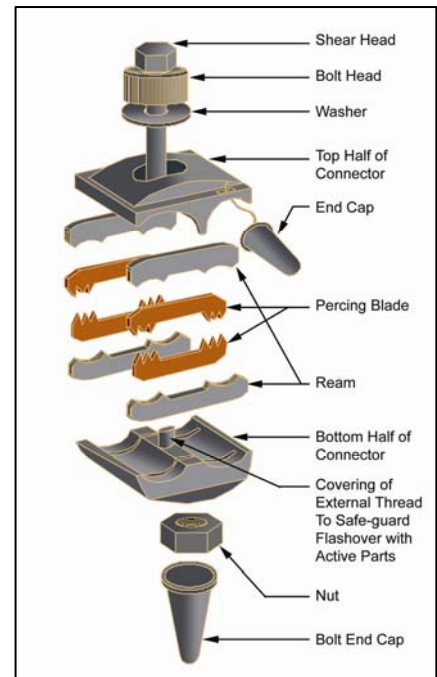

Different components of new generation insulation piercing connector assembly

Advantages of Insulation Piercing Connector

1. The installation of IPC requires tightening of the bolt with the basic wrench and as the Shear head is designed to break at the rated torque, the installation cost is greatly reduced and the problems that may arise due to Over torque or Under torque is eliminated .
2. As the Connector's teeth are designed to pierce the insulation of the conductor to make electrical contact and are pre-filled with an oxide inhibiting compound, the cost of stripping the conductor at the site and the cost of application of the oxide inhibitors are considerably reduced .
3. The body of IPC is of insulated material which avoids the use of tape or special insulation cover.
4. As all the active parts of the cable and the connector are fully enclosed in an insulated enclosure and no contact of installation tools with any of the active parts is required installation without de-energizing the line is possible.
5. IPC assures safety of the installation personnel as the connectors body is fully insulated to withstand 6 KV RMS and the enclosures are tested for protection degree ratings .
6. Hook type Line tapping is not possible with IPC

Limitations of Insulation Piercing Connector

1. The use of IPC is limited to LV applications and only those MV applications which involve only unscreened covered conductors.
2. The use of IPC is restricted to non-tension applications

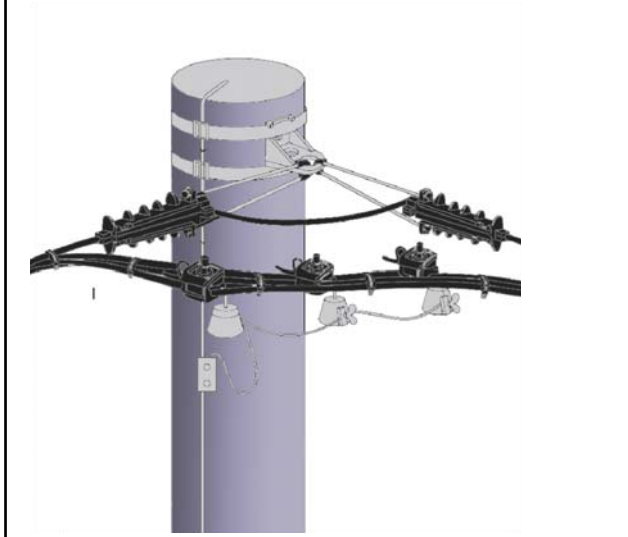
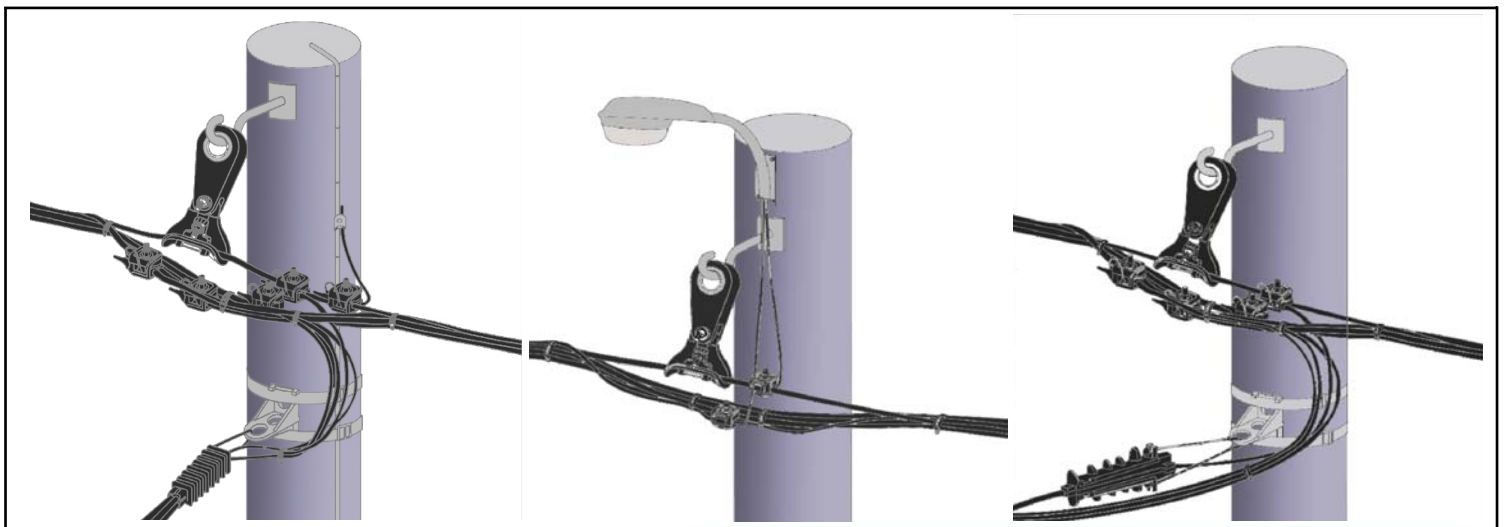

Conceptual Assembly of ABC system including Suspension & Tension Clamp, Piercing connector, pole bracket, pole strap & street light.

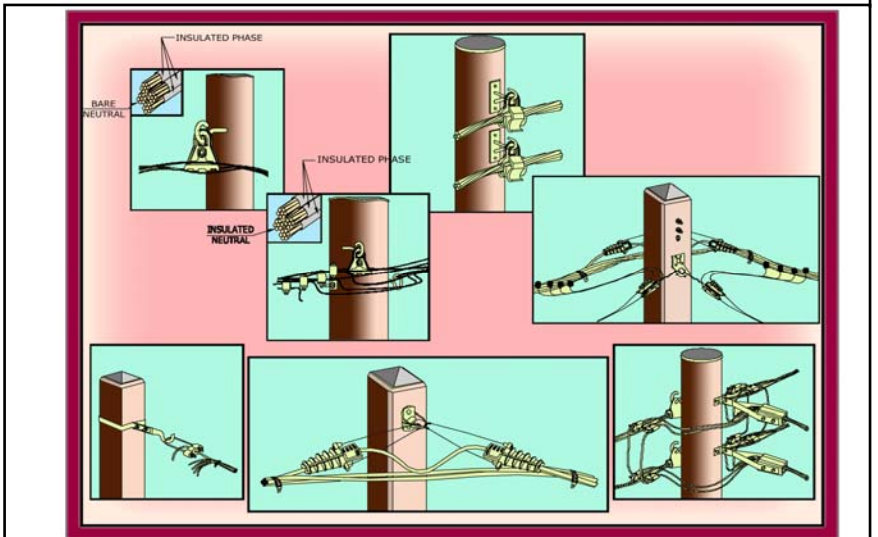

Suspension/ Tension Clamps with pole fittings are in use for three types of ABC systems

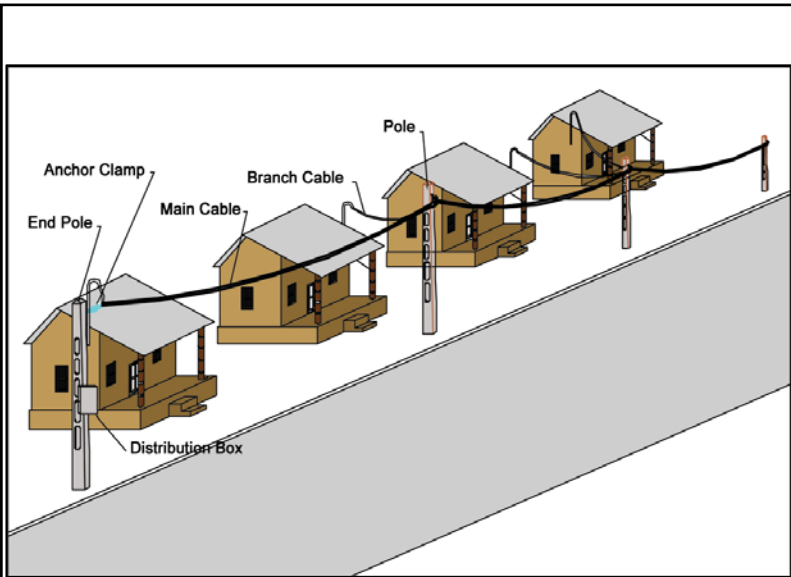

POLE AND WALL ARRANGEMENT

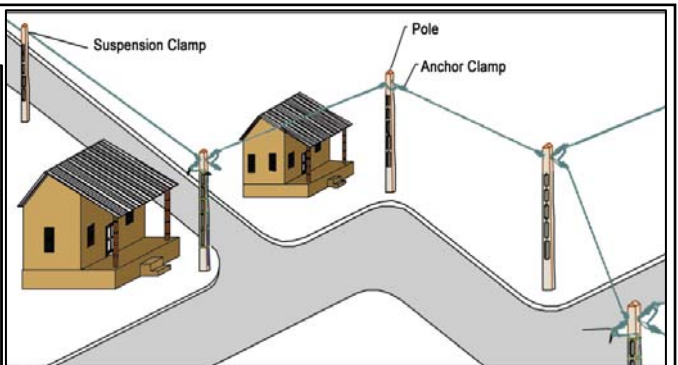

POLE MOUNTING

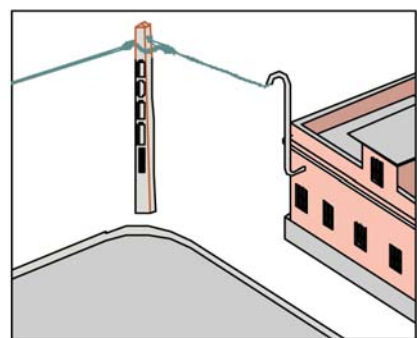

WALL MOUNTING

Conceptual view of ABC Installation - LV

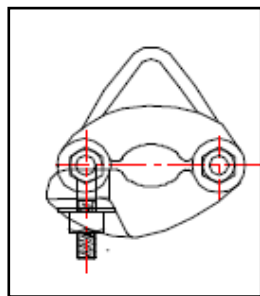

Come along clamp for tensioning over head connectors

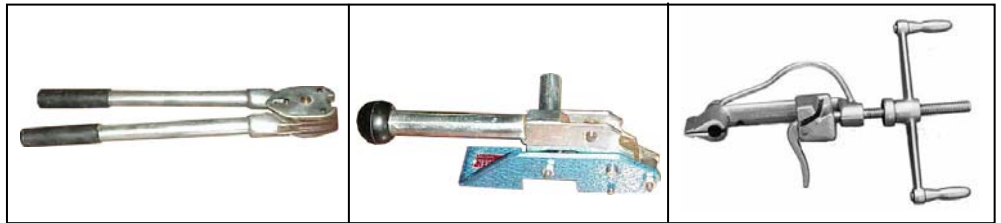

Banding Tools

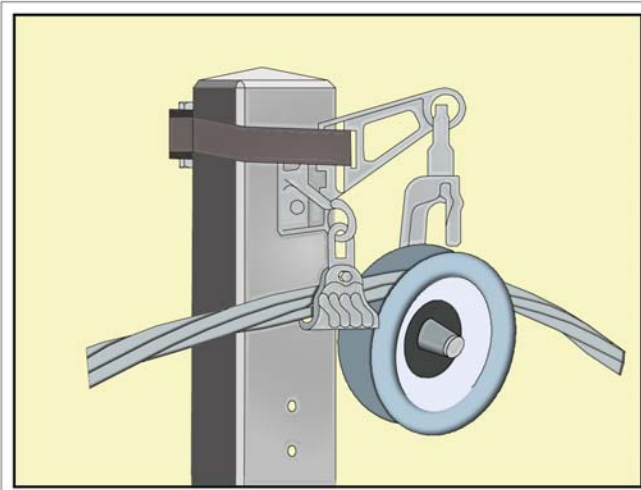

De-mountable pulley with thermoplastic wheel for LV and aluminum alloy wheel with neoprene covering for MV used for pulley in cables for pulling in at angles fitting than 30° two pulleys to be used.

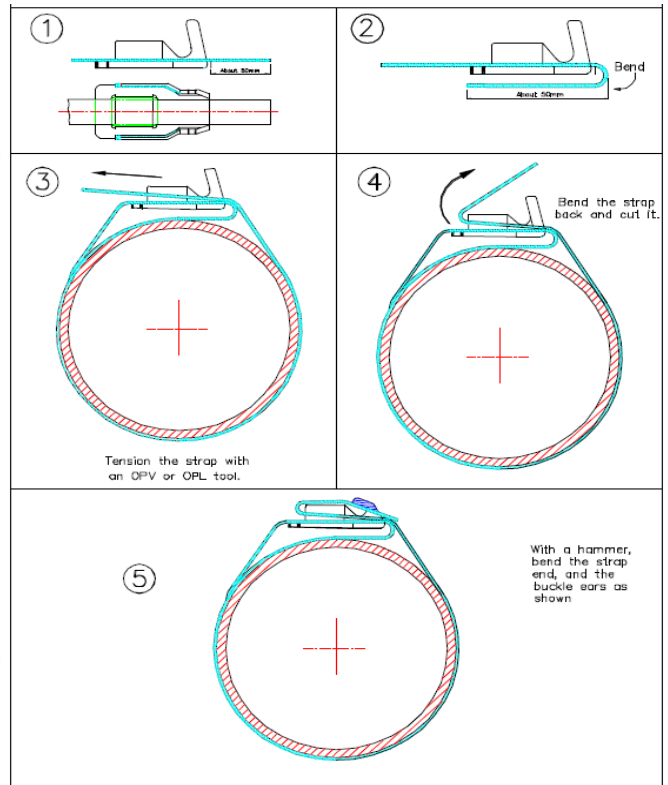

Installation instruction for Banding & Buckles

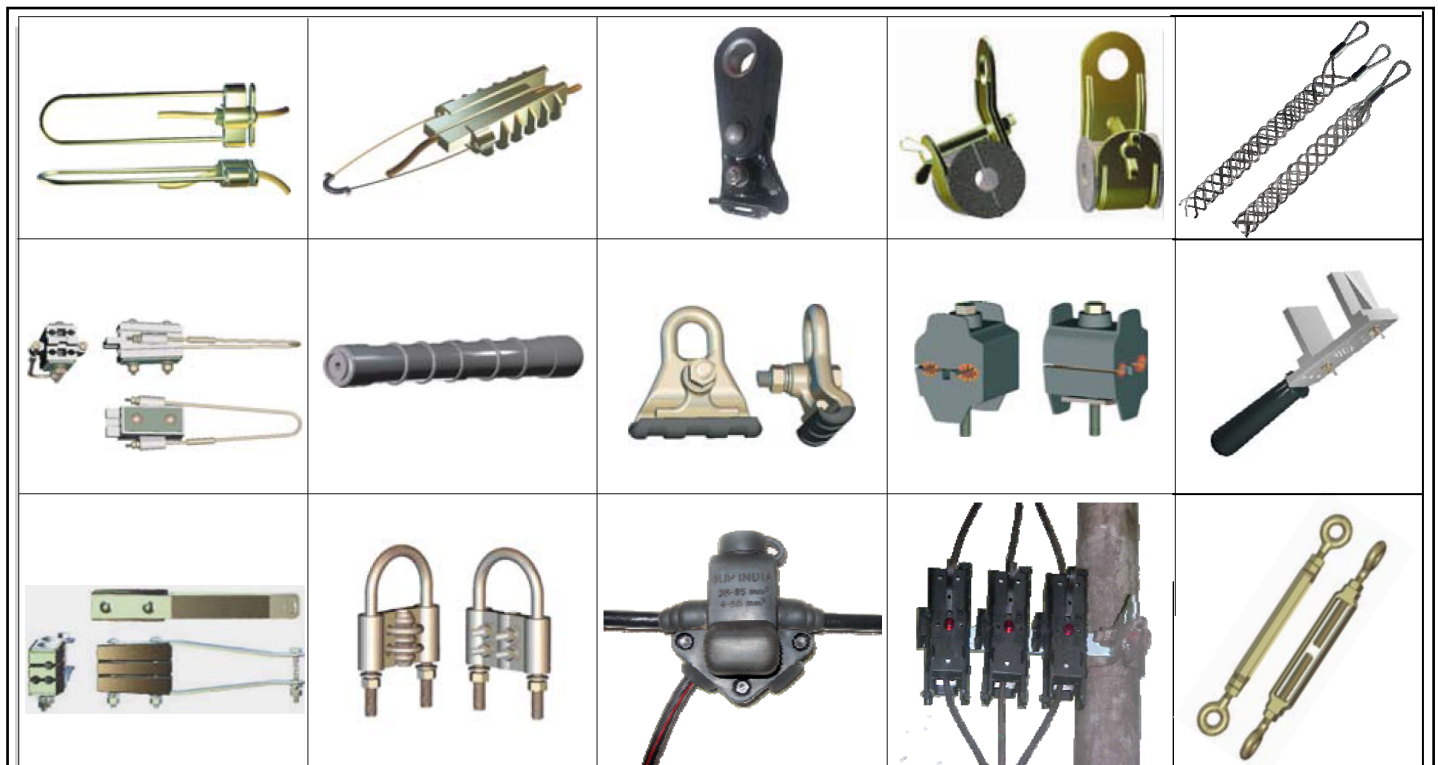

Some of Accessories for ABC system - LV

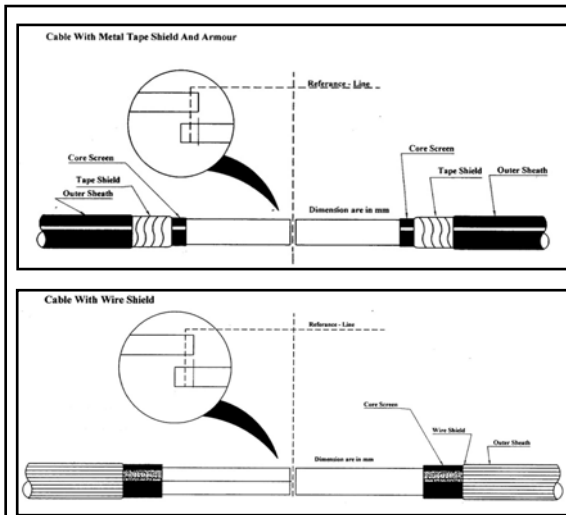

Voltage stress-relief type heat shrinkable joint medium voltage XLPE ABC

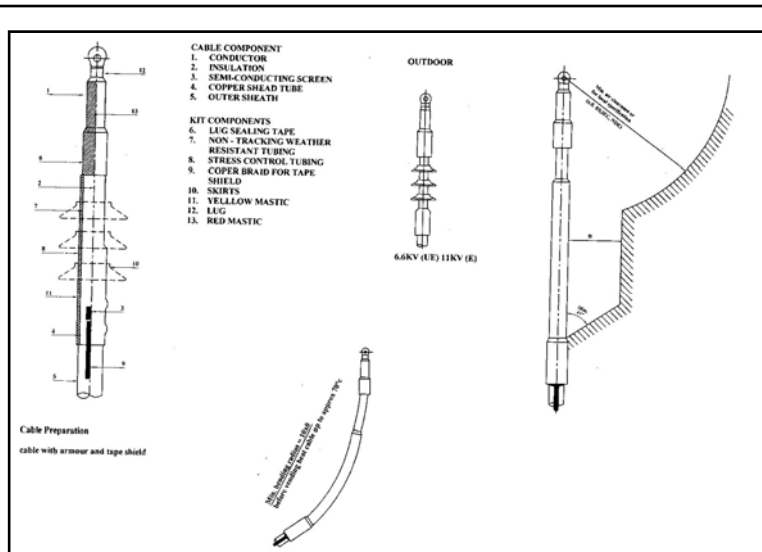

Heat Shrinkable voltage stress-relief type end-terminator for MV ABC

Conclusion

The use of ABC systems for low voltage network and overhead covered / insulated conductors for medium voltage network results in significant advantages to consumers and utilities. The system provides very high degree of reliability in terms of safety to line-men and consumers and freedom from outages. It also has significant environmental benefits like conservation of trees. It permits electrical lines to be taken to extremely congested areas while ensuring safety and freedom from illegal hooking. The ABC system permit HVDS line to be taken into narrow alleyways and slums extremely vulnerable to illegal tapping. However, it is important for network to be installed with support accessories and more importantly connectors of right design and quality. Proper fused disconnection for protection of LV system from over heating is also very important. It may be noted that ABC connector technology has evolved over a period of time with degree of protection rating for insulating enclosures now being significantly higher with the use of water proof connectors in place of weather proof connectors in use during the initial stages of introduction. Without adequate diligence, installing ABC system may well be a self defeating exercise.

Acknowledgement

We acknowledge contributions of ex-employees of Supreme & Co. (P) Ltd. Er. B. Chakoraboty, Jayagouri and Diptendu Sarkar for valued contribution from time to time. We are also grateful to Er. P. P. Singh of M/s. Compaq International, Yamunanagar for encouragement and technical guidance on application of Heat Shrinkable Joints and Terminations.

References

1. **Insulation coordination of MV power cables**
By Teixeira, M.D.R., Jr.; Svenson, M.; Morais de Oliveira, J.
This paper appears in: Power Delivery, IEEE Transactions on
Page(s): 675 - 678, Jul 1999, Volume: 14 Issue:3
2. **HV overhead line-the Scandinavian experience**
By Hart, B.
This paper appears in: Power Engineering Journal
Page(s): 119 - 123, Jun 1994, Volume: 8 Issue:3
3. **Comparative testing of chosen piercing connectors**
By Gacek, Z.; Mazniewski, K.; Sosinski, R.
This paper appears in: Power Delivery, IEEE Transactions on
Page(s): 1122 - 1128, April 2005, Volume: 20 Issue:2
4. **Development and introduction of aerial bundled cables in Australia**
By Williamson, C.E.; Garner, M.P.; Barber, K.W.; Elford, R.F.
This paper appears in: Overhead Line Design and Construction: Theory and Practice, 1989., International Conference on
Page(s): 113 - 117, 28-30 Nov 1988, Volume: Issue:
5. **Minimization of Losses in Radial Distribution System by using HVDS**
By Amaresh, K.; Sivanagaraju, S.; Sankar, V.
This paper appears in: Power Electronics, Drives and Energy Systems, 2006. PEDES '06. International Conference on
Page(s): 1 - 5, 12-15 Dec. 2006, Volume: Issue:
6. **New types of MV distribution overhead lines and LCC-analysis as a method for selecting type**
By Andersson, L.; Svensson, S.; Nylund, J.; Regner, L.
This paper appears in: Electricity Distribution, 1989. CIRED 1989., 10th International Conference on
Page(s): 185 - 189 vol.3, 8-12 May 1989, Volume: Issue:
7. **Design and application of aerial systems using insulated and covered wire and cable**
By Clapp, A.L.; Dagenhart, J.B.; Landinger, C.C.; McAuliffe, J.W.; Thue, W.A.
This paper appears in: Power Delivery, IEEE Transactions on
Page(s): 1006 - 1011, Apr 1997, Volume: 12 Issue:2
8. **The aerial bundled cables (ABC) and the characteristics of its semiconductive shield**
By Oliveira, J.J.S.; Pinheiro, W.; Faria, R.M.; Ruvolo F., A.; Cardoso, J.R.; Nachvalger, E.E.; Dirani, E.A.T.; Fonseca, F.J.; Castro, A.F.; Andrade, A.M.;
Oliveira, R.B.L.; Caron, L.E.
This paper appears in: Electrical Insulation and Dielectric Phenomena, 1996. IEEE 1996 Annual Report of the Conference on
Page(s): 408 - 411 vol.1, 20-23 Oct 1996, Volume: 1 Issue:
9. NFC 041 & 041
Insulated cables and their accessories for power systems Anchoring devices for overhead distribution with bundle assembled cores of rated voltage 0.6/1KV
10. Degrees of protection provided by enclosures (IP Code)
60529 © IEC: 1989 +A1:1999
CEI IEC 1238-1
International Standard
11. Comprehensive Catalogue and Technical Literature for Electrical Connectors
Technical Literature
<http://www.supremeco.com/newsite/literatures.asp>
12. Heat Shrinkable cable joints, terminations & accessories
Technical Literature
<http://www.supremeco.com/newsite/literatures.asp>
13. An insight into design, development & testing of insulation piercing connectors for LV application
Technical Literature
<http://www.supremeco.com/newsite/literatures.asp>
14. T.P. Murray: "Ten years of LV Bundled line developments in Ireland", Distribution 2,000 conference, Sydney, May 1991
15. J. Sebire, S. Piasentin and K. Souprovnovich: "the Development, Introduction and Experience with HV ABC in the State Electricity Commission of Victoria" Distribution 2,000 conference, Melbourne
16. T.P.Murray : "20Kv ABC line to suit Irish Needs", Distribution 2,000 Conference, Melbourne, November 1993
17. P. Quigley and T.P.murray: "Some recent developments in ESB on environmental line design and specification/ design of ABC line components", CIRED, Birmingham, May 1993
18. Safety of Electrical Installations up to 1000 Volts
Wilhelm Rudolph
19. Low Voltage Applications, The Electrical Utilities Safety Association of Ontario.
20. Transmission & Distribution World
21. An investigation into the performance of insulation piercing connectors for use with aerial bunched cable, Thesis Queensland University of Technology, Brisbane, Australia - 1996
22. NS 0109 Network Standard, Volume – I
Design Standards for Overhead Developments
23. Aerial Bundle Conductor
Tom Murray, Distribution Department, ESB, Ireland.